

# **MAXSYS™**

## **Wireless Remote for Festool CT-Series Dust Extractors**



**Owner's Manual**

**RTS ENGINEERING**

## Installation



**WARNING:** Risk of electrocution. Make sure to unplug the dust extractor from electrical supply before opening the module bay or installing Maxsys. The Maxsys circuit board will have live power if the dust extractor is not unplugged.

Maxsys installs in the accessory module bay of any CT-26/36/48 dust extractor.

1. Unplug the dust extractor from electrical power.
2. Using a 5mm hex key, remove the two screws securing the blanking cover to the front panel of the extractor, and remove the blanking cover. (Neither the screws nor the cover will be reused.)
3. To protect the circuit board during shipment, Maxsys is pre-assembled with the circuit board between the adapter plate and cover. Separate the Maxsys cover from the adapter plate and circuit board, by removing the two T15 Torx screws.
4. Connect the larger plug of Maxsys into the power socket in the module bay.
  - The plug fits in only one direction, so do not force it if it doesn't fit.
5. Route the power wires across the module bay so they will be under the adapter plate when you install it.
6. To protect the antenna coil during shipping, it may be tucked in between the vertical circuit board and the blue relay box. Do not uncoil the antenna coil, but gently free it up so it is not trapped along side the vertical (RF Receiver) circuit board. If the antenna is pressed against the receiver board, it can diminish reception distance of the remote.

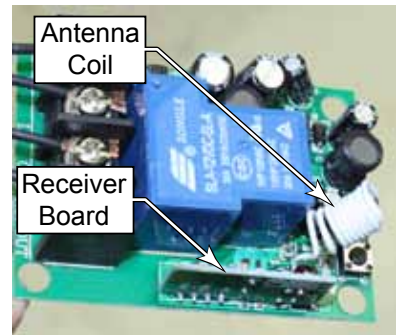
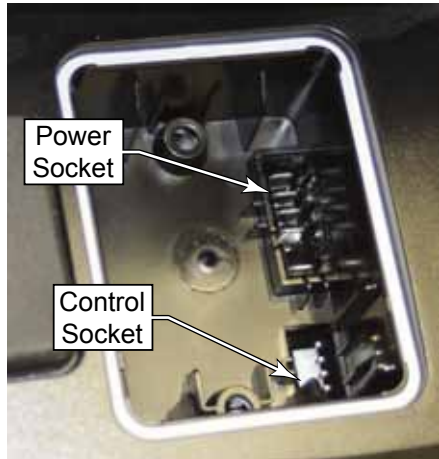

7. Loop the control wires under the adapter plate, and position the control plug in the adapter plate over the control socket.

- The control plug is mounted in the adapter plate to ensure that you cannot plug it in backward. Do not force the adapter plate down if the plug is not lined up.

8. With the control plug lined up with the control socket, press the adapter plate down onto the mounting bosses at the bottom of the module bay.

9. Using the two M6 x 40mm socket head cap screws included in the kit, secure the adapter plate to the dust extractor's front panel.

- Make sure the wires are under the adapter plate, and are not pinched between the plate and the extractor's front panel.

10. Carefully tucking the wires in along side the Maxsys module, position the circuit board onto the standoffs of the adapter plate. (It doesn't matter which end is up. Rotate the circuit board to best fit the wires.)

11. Taking care to not allow the circuit board to come off the standoffs, place the cover plate over the module bay, and secure it with the two T15 Torx screws.

12. For Maxsys to control your extractor's on/off function, the selector switch needs to be set to "Auto".

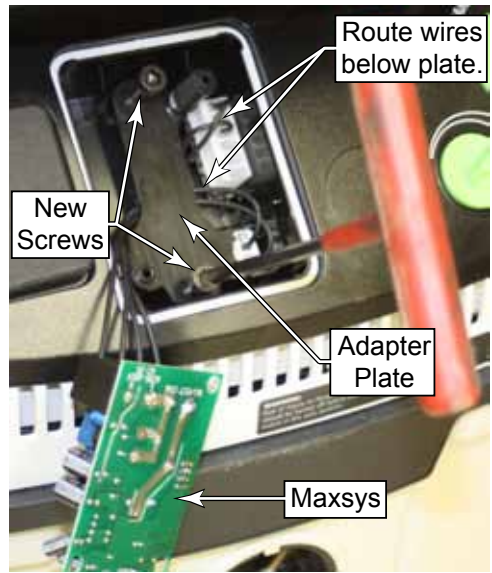

## Configure Multiple Maxsys to Operate from One Remote

Two Maxsys modules can operate from a single remote, where button-A controls one Maxsys, and button-B controls the other. Additional remotes can also be paired for the same operation.

1. Disconnect the dust extractor from electrical power.
2. Remove the module cover plate, and lift the Maxsys circuit board from the module bay.
3. Remove the configuration jumper from it's stowed position, and place it over the left and middle pins for multi-mode operation.

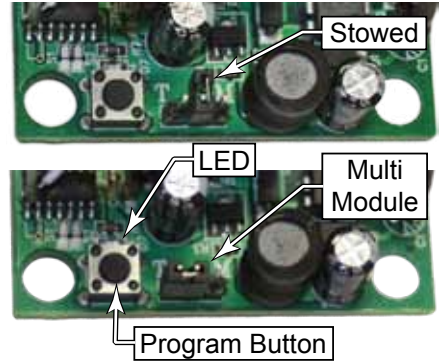

## Pairing Remotes



**WARNING:** *Risk of electrocution. Keep your dust extractor unplugged from power until instructed to do otherwise. This procedure requires your dust extractor to be powered while the circuit board is exposed. Take care to never touch any of the metal pathways of the circuit board while completing this procedure.*

Each Maxsys module can be controlled by multiple remote keyfobs to suit your workshop needs. You can program the Maxsys module for new remotes, or you can clear all previously programmed remotes.

1. Disconnect the dust extractor from electrical power.
2. Remove the module bay cover.
3. Lift the circuit board off the standoffs, flip it over so the components are facing upward, and loosely install one screw into one standoff to hold the circuit board in place while you finish the programming.



**From this point forward, do not touch the circuit board with any part of your body, or any conductive object!**

4. After ensuring that the circuit board is not in contact with any conductive objects, plug your extractor in and turn the selector switch to “Auto”.
5. **Using a non-conductive object**, such as a strip of wood or plastic pen, press the programming button. The LED light adjacent to the button will turn on.
  - To clear all memory, continue holding the button for about 8 seconds, until the LED light begins to flash, and then release the button.
  - To pair a new remote, simply press the button once, and the LED will turn on and stay on until it receives a valid transmitter signal.
6. Press the “On” button on the remote you wish to program. The LED will turn off and the remote has been programmed into memory.
7. Unplug the extractor from electrical power, and re-install the Maxsys circuit board and cover.